

# BUITING STAALBOUW

Buiting



machinebouw &  
staalconstructie b.v.

Tel.: 0570 - 531010 • Fax: 0570 - 531012  
e-mail: [buiting.net@hetnet.nl](mailto:buiting.net@hetnet.nl) • [www.buitingstaalbouw.nl](http://www.buitingstaalbouw.nl)

## Avondsessie Rotocoat 10-5-2017

lid  
koninklijke  
**metaalunie**

Samenwerkende  
Nederlandse  
Staalbouw



# BEDRIJF



- Gestart 1996
- Ca 95 medewerkers in vast dienstverband
  - 5 Projectleiders – 9 engineers – 1 constructeur
  - 2 montageleiders – 8 eigen montageploegen
- 2 Productie locaties: Almelo / Broekland
- 14.000 m<sup>2</sup> productie - 2.000 m<sup>2</sup> kantoor

# PROJECTEN GEREED

- Staalconstructie opbouw toren A'dam 2015

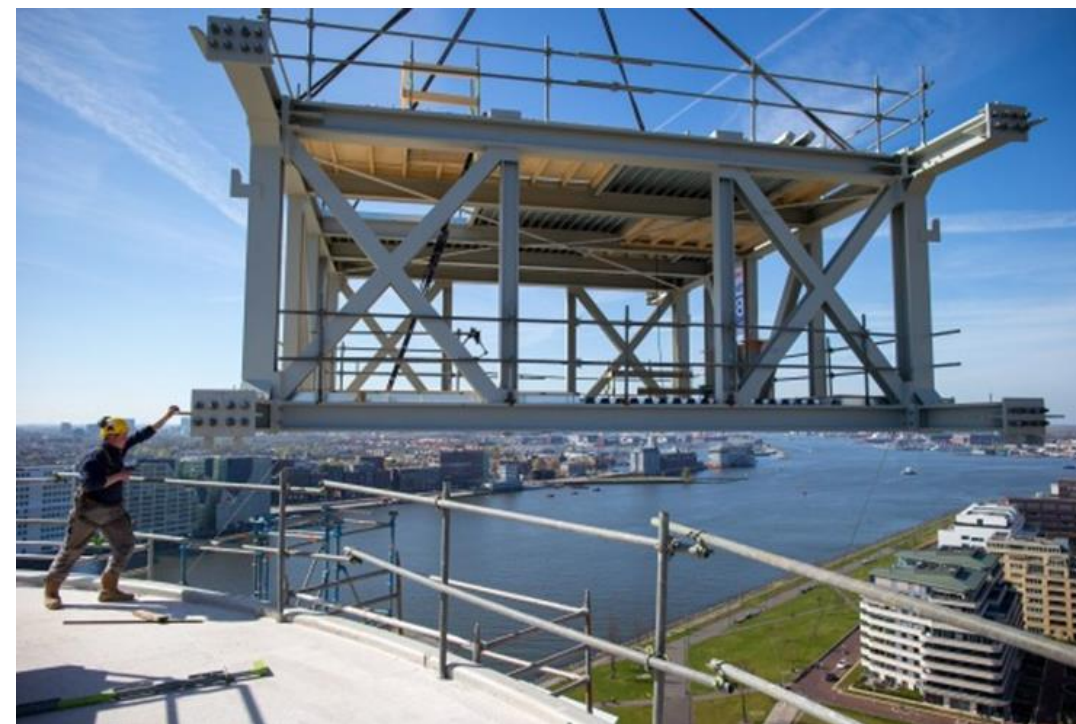

## ■ Appartementencomplex Ponsteiger Amsterdam

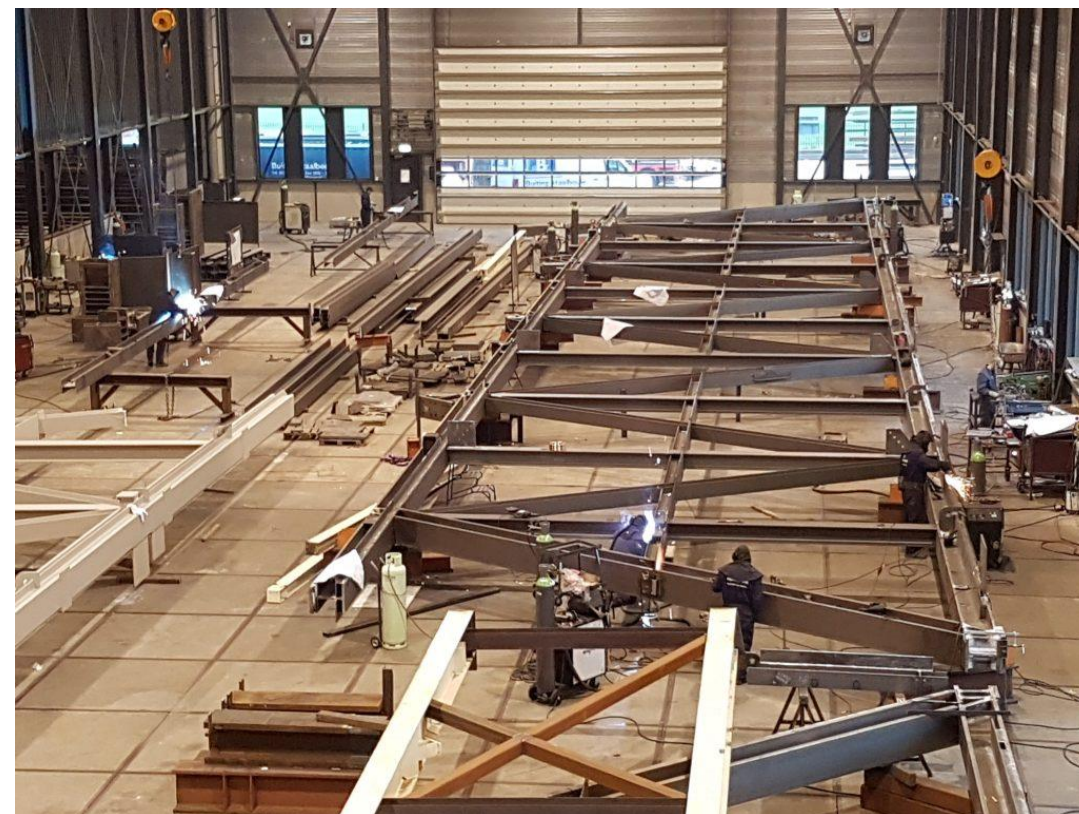

# PROJECTEN VERZINKT DATACENTER

## ■ Algemeen

- Afmetingen 55x30x72 meter.
- Totaal ca 1600 ton staal.
- Ca. 120 ton thermisch verzinkt.

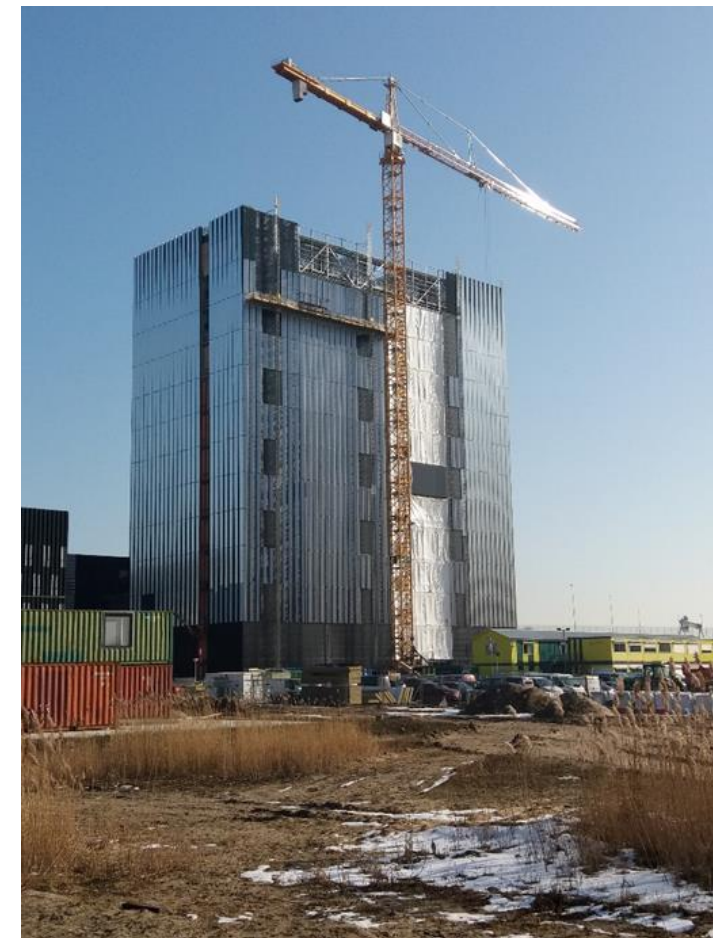

# PROJECTEN VERZINKT DATACENTER

## ■ Bovenbouw

- Afmetingen 55x30x8,5 meter.
- Ca 55 ton verzinkte staalconstructie

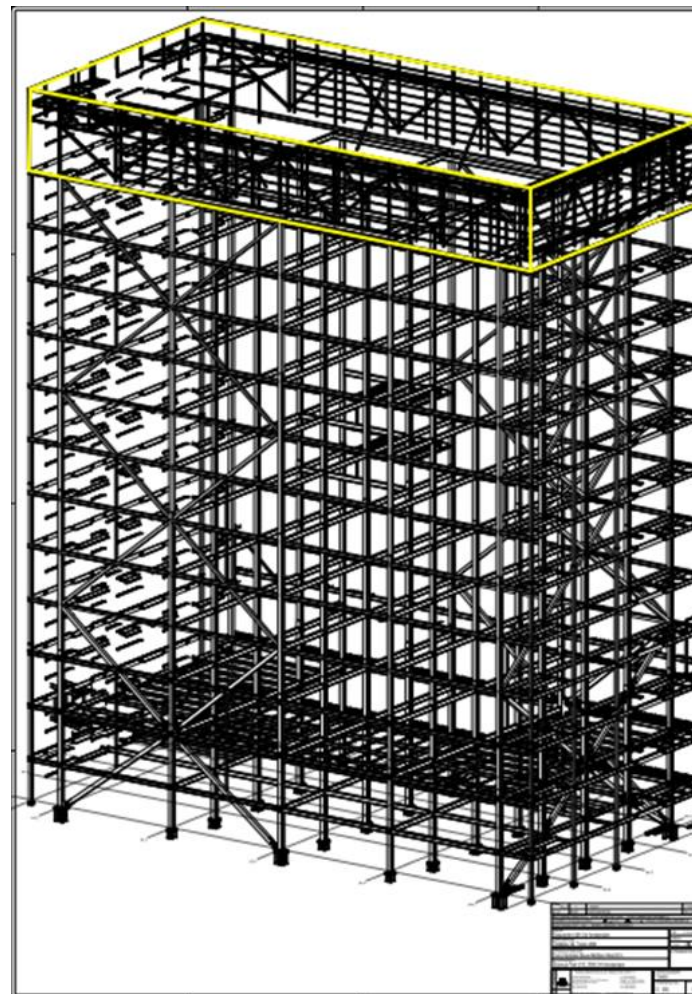

# PROJECTEN VERZINKT DATACENTER

Buiting



machinebouw &  
staalconstructie b.v.

Tel.: 0570 - 531010 • Fax: 0570 - 531012  
e-mail: [buiting.net@hetnet.nl](mailto:buiting.net@hetnet.nl) • [www.buitingstaalbouw.nl](http://www.buitingstaalbouw.nl)

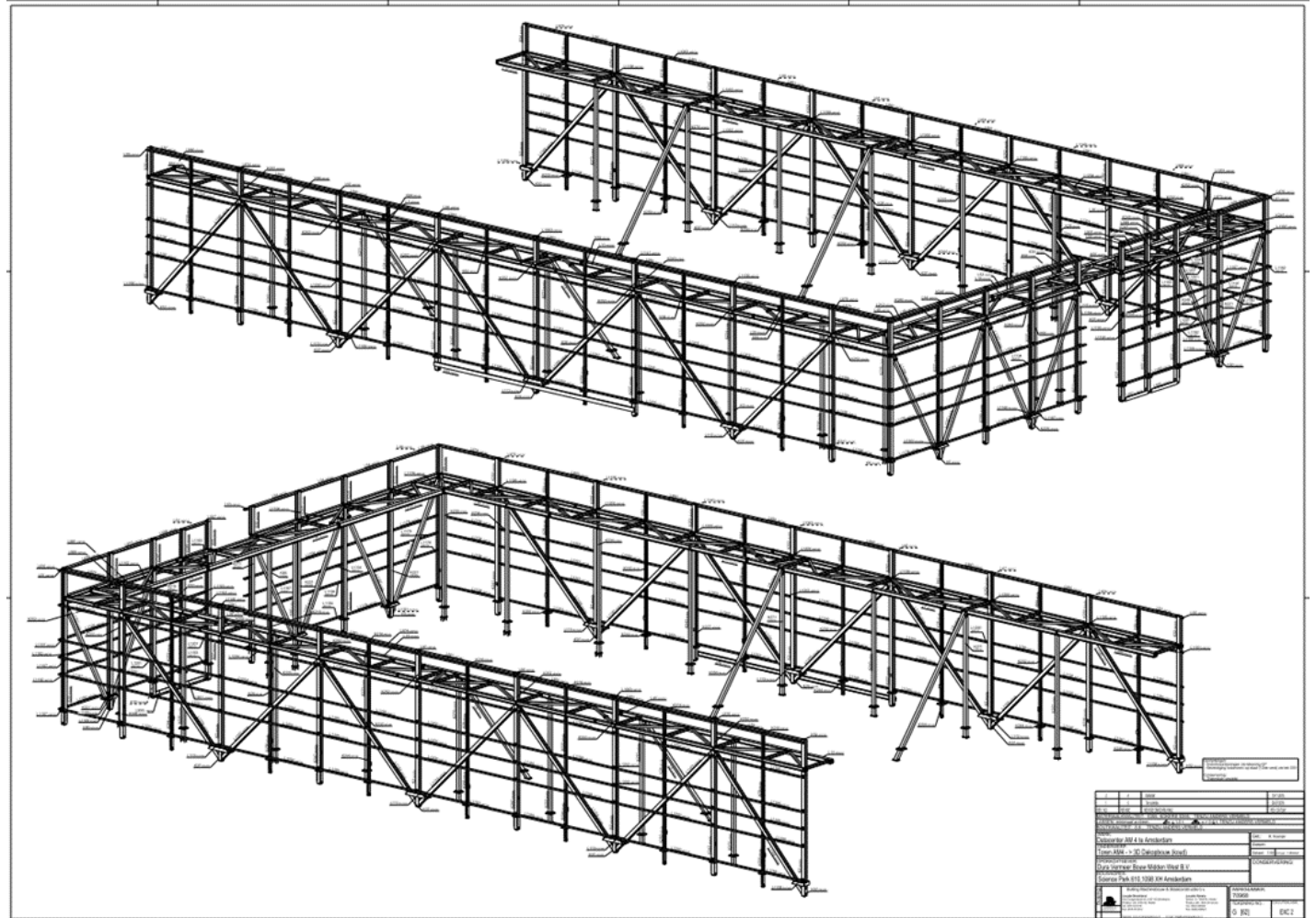
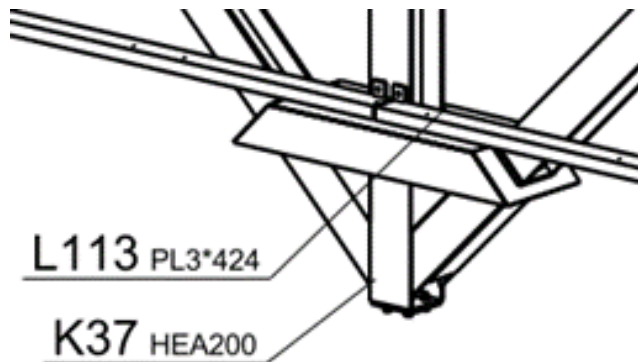

# PROJECTEN VERZINKT DATACENTER

Buiting



machinebouw & staalconstructie b.v.

Tel: 0570 - 531010 • Fax: 0570 - 531012  
e-mail: [buiting.net@hetnet.nl](mailto:buiting.net@hetnet.nl) • [www.buitingstaalbouw.nl](http://www.buitingstaalbouw.nl)

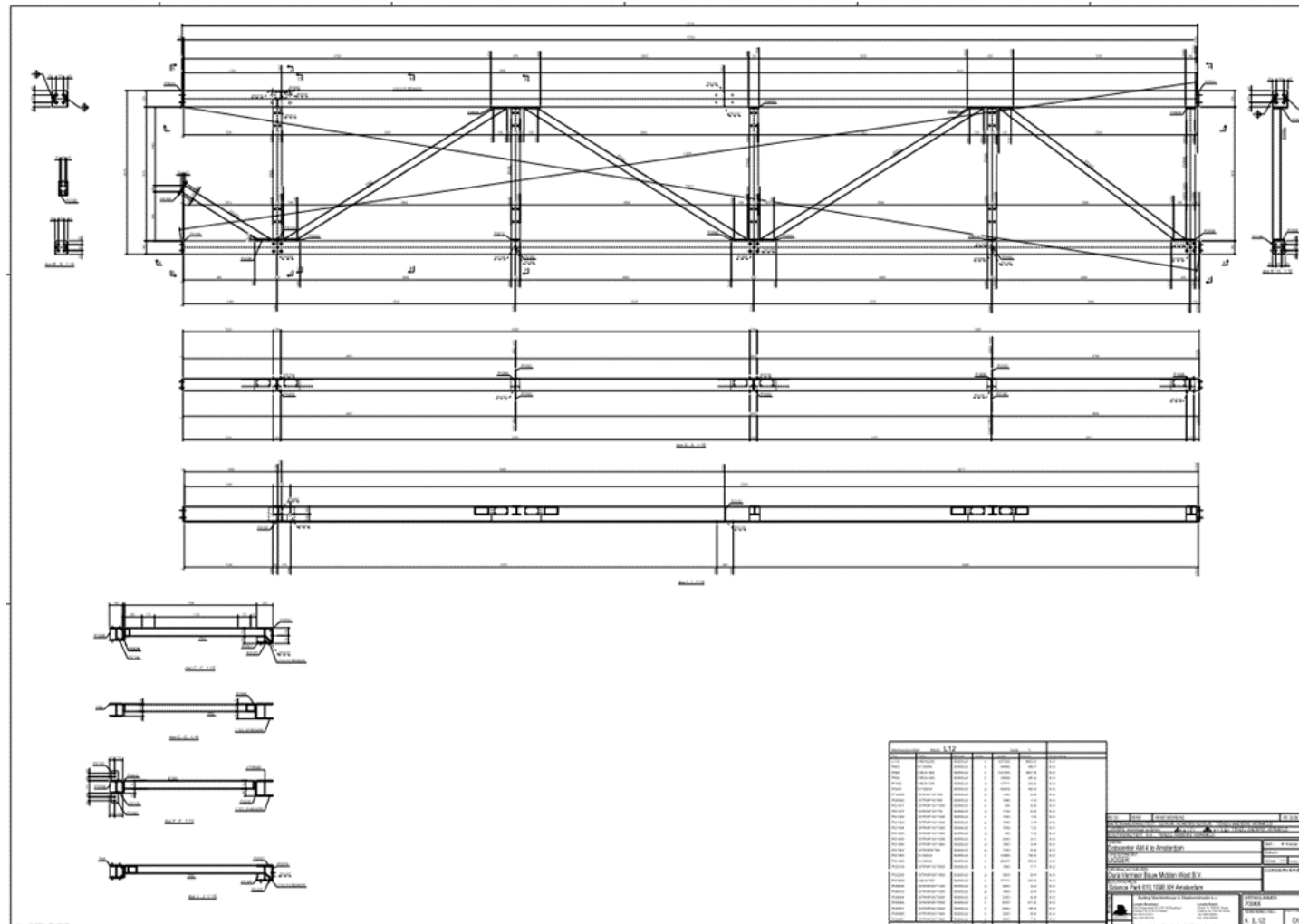



# PROJECTEN VERZINKT DATACENTER

## ■ Tafelconstructie

- Afmetingen 40x30x1,5 meter.
- Ca. 65 ton thermisch verzinkte staalconstructie

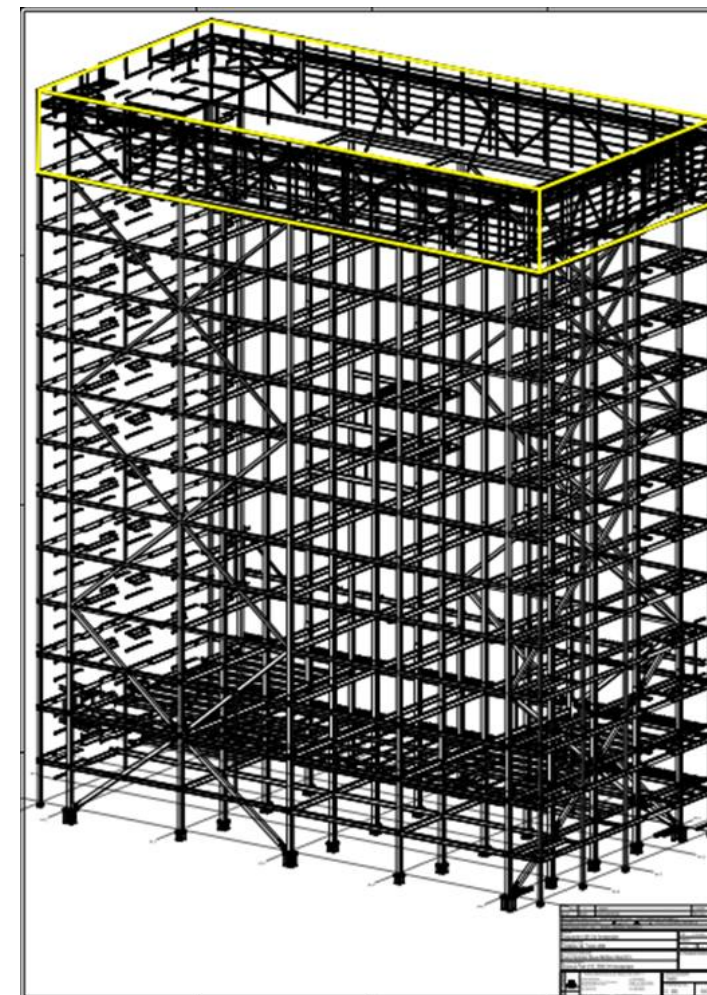

# PROJECTEN VERZINKT DATACENTER

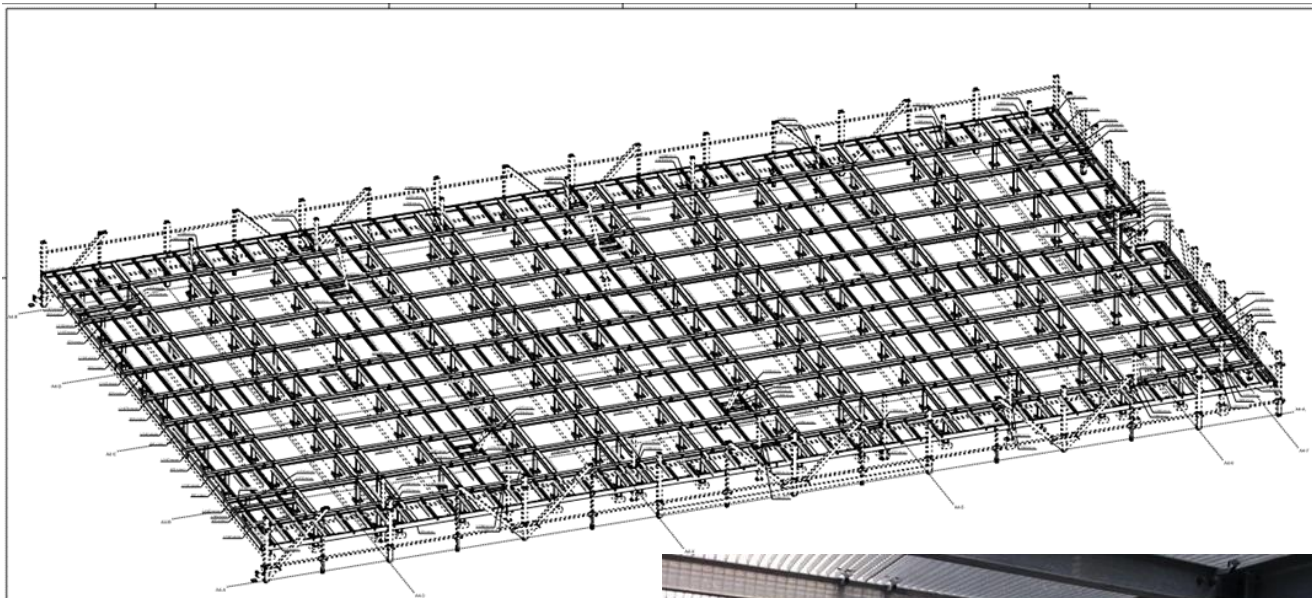

# PROJECTEN VERZINKT DATACENTER

## ■ Kwaliteit

- Inzet op verhoogde kwaliteitseis vanuit scope.
- Bedrijfsbezoek Rotocoat met klant.
- Alles onder FAT Rotocoat – Factory Acceptance Test.
- Opname met Buiting, Rotocoat en klant.
- Nazorg.
- Definitief opleveren

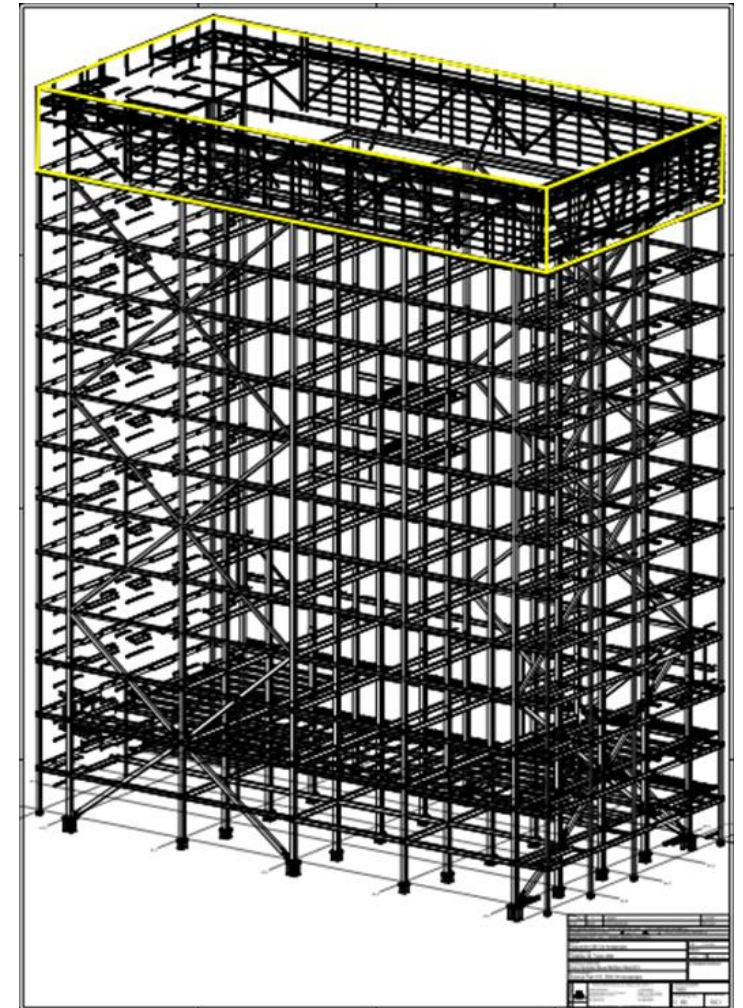

# PROJECTEN VERZINKT DATACENTER



<b>Location:</b>	Rotocoat Heerhugowaard
<b>Adress:</b>	Edisonstraat 2 1704 RL HEERHUGOWAARD 0725 - 76 21 50

Factory Acceptance Test (FAT) - inspection of hot-dip galvanized material	
<b>Project:</b>	DATA AMS 4
<b>Projectnumber:</b>	70968 - 207
<b>Fase:</b>	B 654401
<b>Client:</b>	Buiting Staalbouw
<b>Order number Rotocoat:</b>	220436

Finishing / Accomplishment:	Yes:	No:	Comments:
Construction undamaged	x		
Zinc layer undamaged	x		
Free of flux residues and white rust		x	Inclosed pictures
Free of hardspelter and scharp points	x		
Properly stored	x		
Measurement report (NEN 1461)	x		
<b>General impression:</b>	Properly hot-dip galvanizing work;		

**Discrepancies:**  
 In the bottom of the HEA-frame sitting bumps as a result of the closure of the beam, the zinc can't flow out properly.  
 (In total 3 pictures inclosed)

**Correcting measures:**  
 None, there is enough zinc on the material it's just pimpy / rough;  
 On the inclosed pictures you see flux residues (ashes), which is removed enduring the trailround. The pictures are token directly after the galvanizing proces before we checked and recovered the material;

<b>For approval Rotocoat:</b>	
<b>Name:</b>	Casper Moes
<b>Function:</b>	Facility Manager
<b>Date:</b>	December 14th 2016
<b>Signature:</b>	

<b>For approval client:</b>	
<b>Name:</b>	
<b>Function:</b>	
<b>Date:</b>	
<b>Signature:</b>	



# PROJECTEN VERZINKT STATION ZWOLLE CS

## ■ Algemeen

- 4 perrons in totaal 450 meter perronkap.
- Constructie volledig thermisch verzinkt.
- Voorzien van 3 lagen natlak / brandwerkende coating

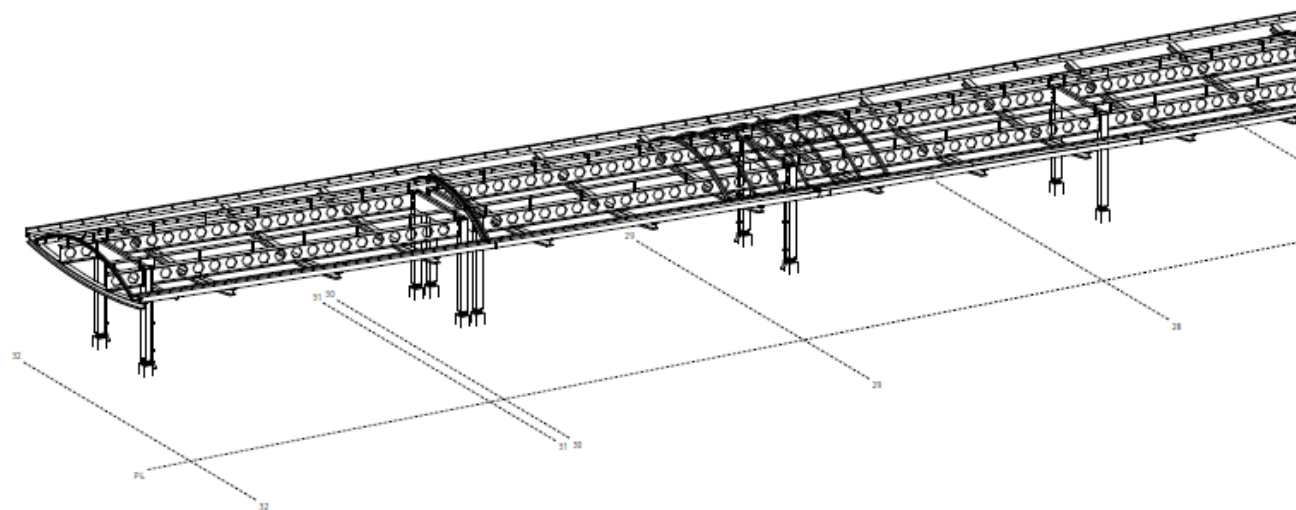

# PROJECTEN VERZINKT STATION ZWOLLE CS

## ■ Breedportalen

- Samenstellen in 3 delen ( 2x kolom en 1x ligger) i.v.m. formaat zinkbad
- 3 delen afzonderlijk verzinken
- Na verzinken delen samenstellen en lassen en vervolgens de lassen bijwerken d.m.v. schoperen

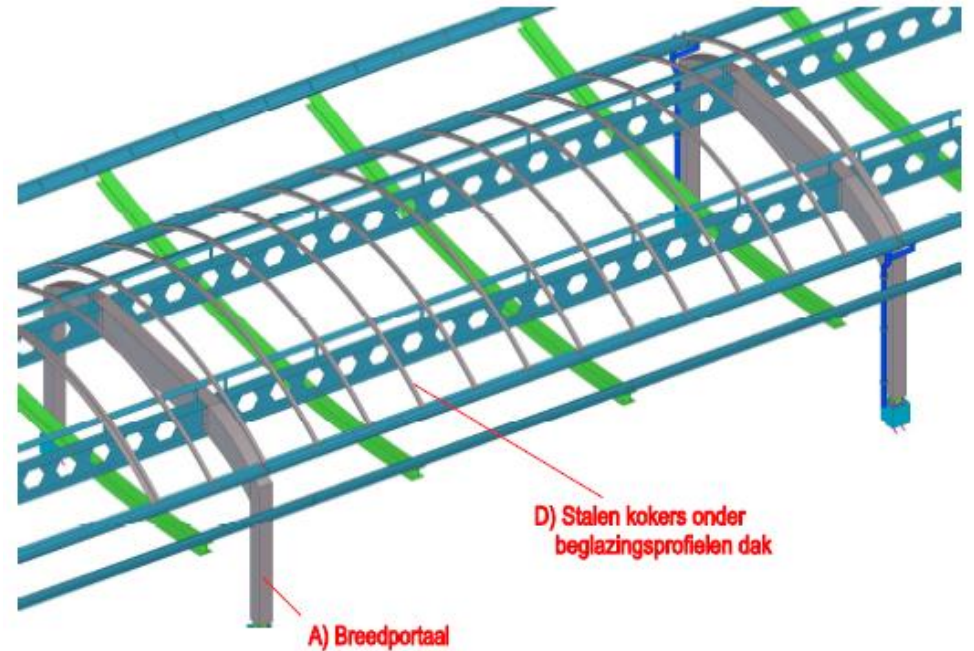
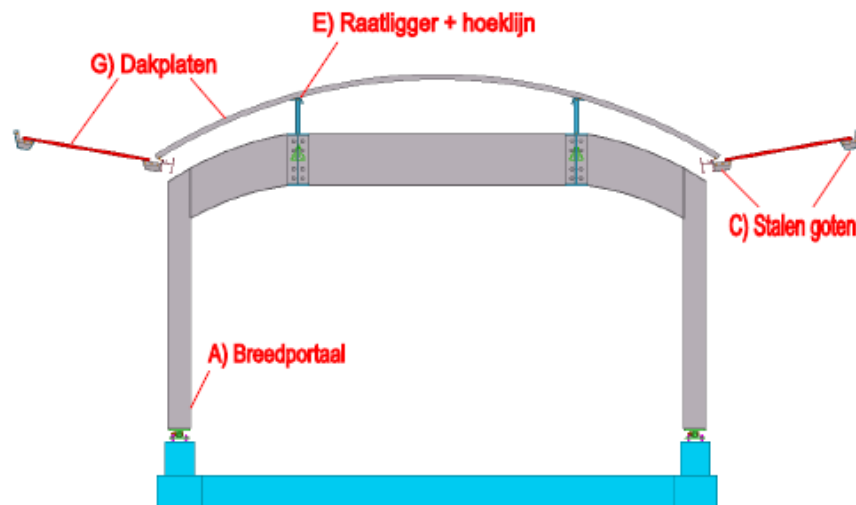

# PROJECTEN VERZINKT LUIFEL STATIONS PLEIN OOST UTRECHT

## ■ Algemeen

- Afmetingen 72x68x25 meter
- Ca 700 ton staalconstructie
- Ca 170 ton thermisch verzinkt.



# PROJECTEN VERZINKT LUIFEL STATIONS PLEIN OOST UTRECHT

## ■ Droogloopconstructie

- Droogloopconstructie van 72x68x1,8 meter rustend op 7 kolommen 25 meter boven plein niveau
- Ca 600 ton droogloopconstructie opgebouwd uit 130 modules







# PROJECTEN VERZINKT LUIFEL STATIONS PLEIN OOST UTRECHT

Buiting



machinebouw & staalconstructie b.v.

Tel: 0570 - 531010 • Fax: 0570 - 531012  
e-mail: [buiting.net@hetnet.nl](mailto:buiting.net@hetnet.nl) • [www.buitingstaalbouw.nl](http://www.buitingstaalbouw.nl)

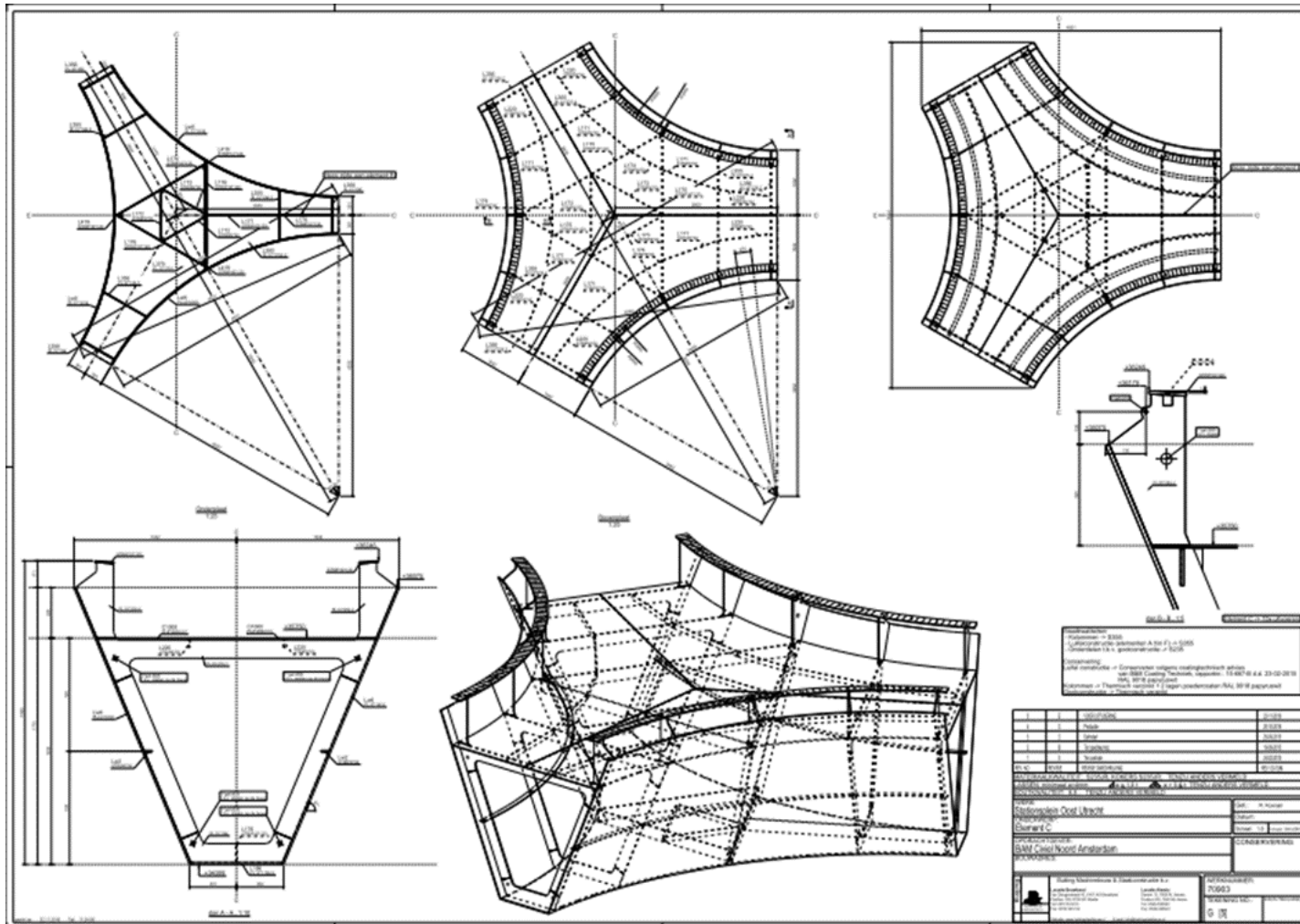

# PROJECTEN VERZINKT LUIFEL STATIONS PLEIN OOST UTRECHT

## ■ Kolommen

- 7 kolommen rond 1300, lang ca. 25 meter.
- Ca 100 ton totaal.
- Ca 100 ton verzinkt.
- Aanvullend natlakken.



# PROJECTEN VERZINKT LUIFEL STATIONS PLEIN OOST UTRECHT

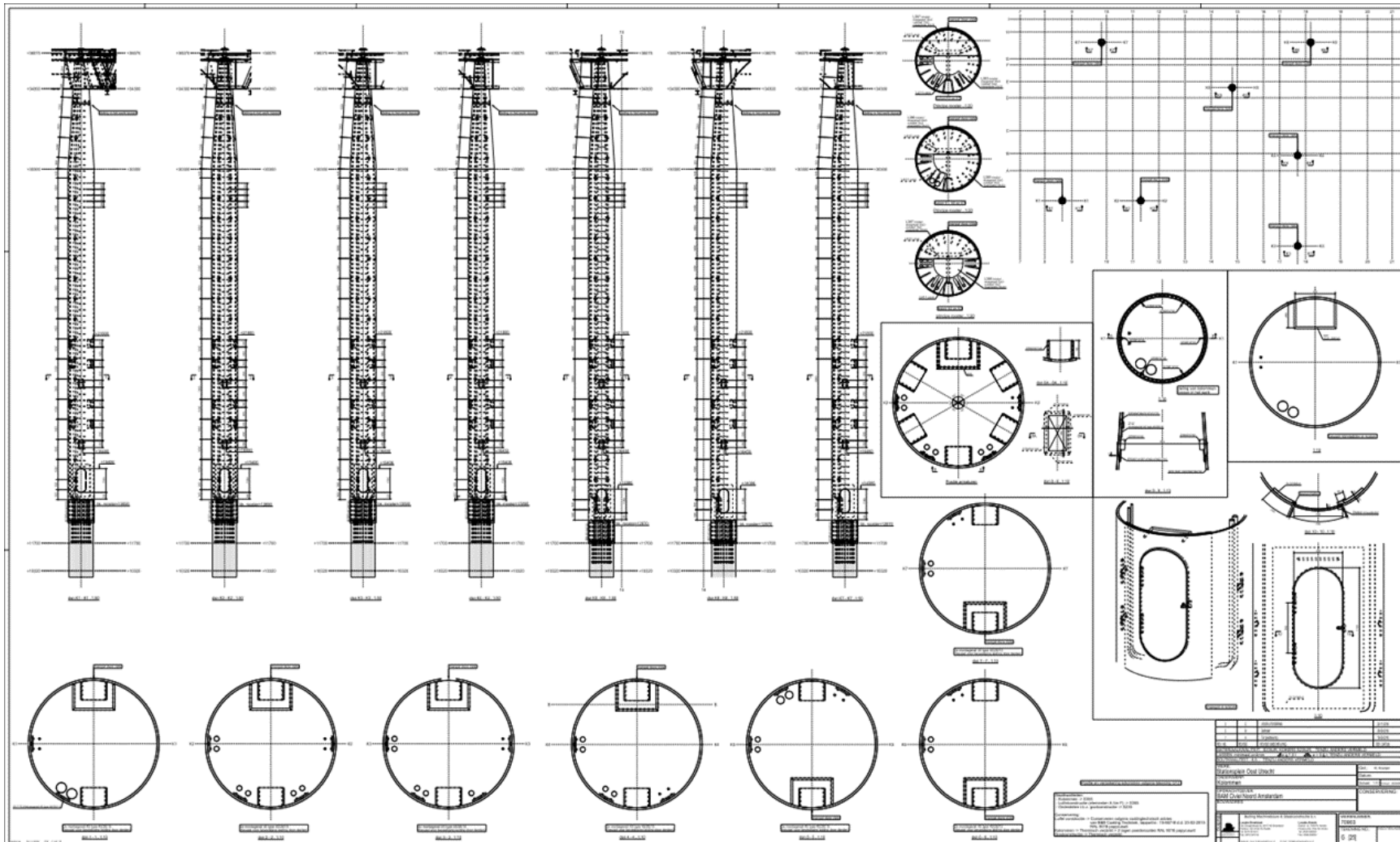

# PROJECTEN VERZINKT LUIFEL STATIONS PLEIN OOST UTRECHT

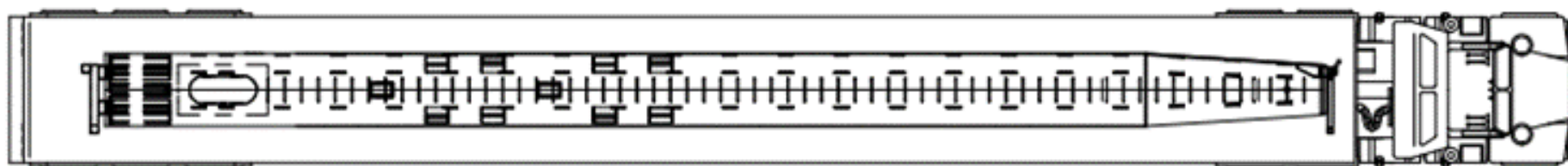

gewicht kolom 14800 kg

# PROJECTEN VERZINKT LUIFEL STATIONS PLEIN OOST UTRECHT



# PROJECTEN VERZINKT LUIFEL STATIONS PLEIN OOST UTRECHT



# PROJECTEN VERZINKT LUIFEL STATIONS PLEIN OOST UTRECHT

## ■ Kwaliteit

- Reguliere kwaliteitsniveau vanuit scope.
- Double-dip i.v.m. lengte
- Communicatie / afstemming vooraf Rotocoat / Buiting
- Verzinken buiten reguliere werktijden i.v.m. afmetingen
- Kwaliteitscontrole en vrijgave voor natlakken

